



# Recommended Material Handling & Impregnation Procedures

POWERCOAT™

N-E  
Nutrient Enhancer

## THE PRODUCT

PowerCoat™ is an oil based emulsified formulation. To optimize impregnation results, Mosaic Biosciences™ has developed recommended procedures for handling and impregnation. Following these procedures will insure proper application and efficacy of the product.

## PowerCoat PHYSICAL PROPERTIES

Density	0.96 +/- 0.02 g/ml
Freezing Point	2°C
pH	6 to 7
Viscosity	363 cps @ 23°C
Vapor Pressure	<1 mmHg @ 20°C
Specific Gravity	0.818-0.881 @ 25°C
Appearance	Dark Brown Liquid Solution

## HANDLING & SITE CONDITIONS

- Store product in original container with cap tightly secured. Store in a dry area out of direct sunlight at 4° to 35°C (40° to 95°F).
- PowerCoat has a shelf life of 24 months in concentrate.
- Do not mix PowerCoat with products that have extreme basic or acidic pH. Do not mix PowerCoat with biocides (bactericides). Do not mix PowerCoat with cleaning products (caustic soda, bleach, phosphoric acid, muriatic acid).
- Apply PowerCoat to dry fertilizer after any curing or procedures involving temperatures above 121°C (250°F).

- PPE
  - Ventilation: Under normal conditions, none required. If drift occurs, wear breathing apparatus.
  - Gloves: May be worn by individuals with sensitive skin.
  - Eyes: Under normal conditions, none required. If potential for drift exists, wear goggles.

## APPLICATION & IMPREGNATION RATE

- The minimum effective PowerCoat rate per acre is determined by fertilizer placement.
  - 2.5 fl oz/A for banded applications (fertilizer that is applied banded in a row).
  - 5 fl oz/A for broadcast applications (fertilizer that is applied broadcast to the entire surface area of one acre).
- The recommended impregnation rate of 22 fl oz to 102 fl oz per short ton of bulk dry fertilizer is dependent on placement and rate of fertilizer. This allows for a variable impregnation rate of PowerCoat to dry fertilizer.
  - **Refer to PowerCoat Impregnation Calculator for specific rates per short ton of bulk dry fertilizer.**
- For best results, apply PowerCoat to the finished formulated blend of dry fertilizer. If applying to only one component of the blend, use that components application rate when entering “fertilizer application rate” in the PowerCoat Impregnation Calculator.
- Any reduction from the rates specified will result in reduced concentration and density of the active ingredient across the dry fertilizer.
- Apply PowerCoat impregnated fertilizer during the normal fertilizer schedule.

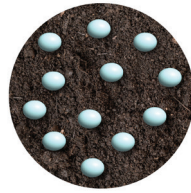

BROADCAST PLACEMENT



BANDED PLACEMENT

## IMPREGNATION PROCESS & REQUIREMENTS

- The impregnation process must be done at a commercial fertilizer or retailer that is equipped for this type of process.
- Agitation
  - It is recommended to properly agitate PowerCoat using a tote mixer for a minimum of 15 minutes prior to application. For example, the [4-blade Collapsible Impeller by DynaMix](#) includes a quick connect drive that can be de-coupled by one operator for ease of installation or removal of the agitator.
  - The microorganisms within the PowerCoat formulation are stabilized. Air (oxygen) does not affect the shelf life of the product. However, direct air injection as a form of agitation can potentially produce foam formation and must be monitored.
- Pump
  - A mechanically actuated diaphragm, or positive displacement, pump is recommended. For example, the [EXCEL XR Pump](#) series are compact and have a built-in flow rate display for ease of programming and flow adjustment. Flow ranges are displayed below relative to dry fertilizer throughput to aid in pump selection.
  - **\*\*Note that the distance and elevation change between pump and spray nozzle should be evaluated for each location to ensure that the selected pump will provide enough pressure at the spray nozzle.**

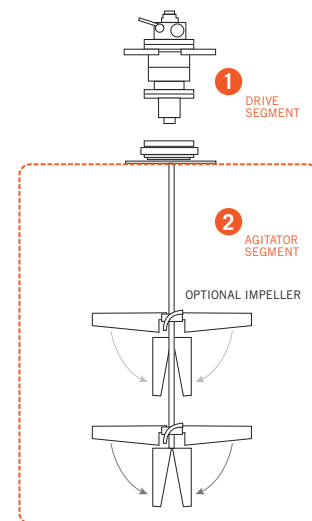

Dry Fertilizer Throughput (kg/hr)	PowerCoat Flowrates (low, L/hr)	PowerCoat Flowrates (high, L/hr)	Recommended Pump
2,500	1.75	8.25	XRDX2 - 21.2 LPH @ 12 bar
5,000	3.5	16.5	
10,000	7	33	XREX3 - 106 LPH @ 6.9 bar
20,000	14	66	
30,000	21	99	
40,000	28	132	XREX4 - 200.6 LPH @ 4.1 bar
50,000	35	165	

Available EXCEL XR Pump series ranges:

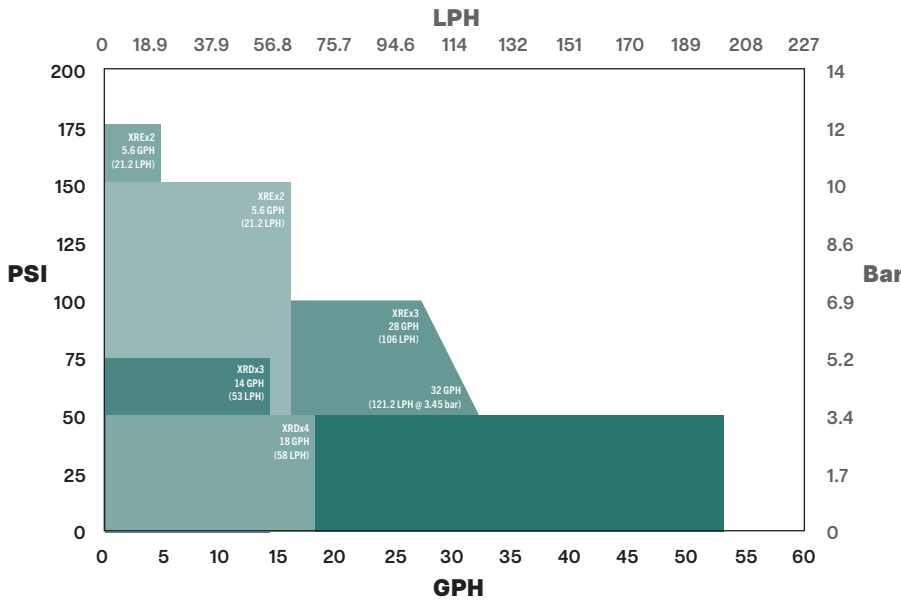

- Piping
  - o Manufacturer recommends applicator utilize stainless steel piping to allow for more effective pipe cleaning after PowerCoat applications. Type 304 and 316 austenitic stainless steels are common selections and readily available. Alternative piping systems such as PVC, plastic, and hose are suitable for PowerCoat applications, though some additional consideration for cleaning the lines after use may be required.
  - o It is recommended that piping/hose systems are run at a minimum 1” diameter due to the semi-viscous properties of PowerCoat. Smaller diameter lines may put the applicator at risk of plugging during/between treatments. It is advised that longer pipe runs (greater than 50 meters total length, greater than 15-meter elevation changes) be reviewed prior to implementation.
- Spray Nozzle
  - o Spray nozzle selection is dependent on treatment rates and treatment equipment types. [Spraying Systems](#) has a large selection of treatment nozzles and their available treatment ranges. Full cone spray nozzles are preferred in batch mixers to improve coverage during mixing. To select a nozzle for a specific application, the retailer must know the batch mixer capacity, batch mixing time, preferred nozzle arrangement, pumping capacity available.
  - o Standard flat spray nozzles are suitable to install in a closed screw auger. The retailer should be able to provide an estimated treatment rate (can be a range if dry fertilizer throughput can be variable), pump pressure at treatment rates, auger trough height, and preferred nozzle count.
  - o One nozzle often does not “fit all” – it is important to select the proper nozzle(s) for your treatment system to ensure dry product is not over or under treated.

- Cleaning
  - The spray lines and vessels can be cleaned if no additional batches of PowerCoat impregnated fertilizer are planned for the same day.
  - Cleaning is encouraged to avoid the building of biofilms inside the pipelines. Cleaning can be done by flushing the spray lines and rinsing the walls of the vessel with sufficient warm tap water. Detergent can also be used to further remove any traces of product in the pipelines (followed by rinsing with water). CIP units can also be used to clean the pipelines and vessels.
  - If impregnating in colder conditions, recommend line blow out after application to mitigate plugging at the nozzle.

## MATERIAL COMPATIBILITY

The table below summarizes the compatibility of PowerCoat with a number of dry fertilizers, amendments and coatings. For material compatibilities not listed please contact [mb.agronomy@mosaicco.com](mailto:mb.agronomy@mosaicco.com).

PowerCoat Dry Materials / Coatings Compatibility Table		
Material	Compatible	Max Shelf Life
<b>Dry Fertilizers</b>		
MicroEssentials® SZ® (12-40-0-10S-1Zn)	yes	12 months
MicroEssentials® 10 (12-40-0-10S)	yes	18 months
MicroEssentials® 15 (12-40-0-15S)	yes	18 months
Aspire® (0-0-0-58-0.5B)	yes	18 months
Pegasus® (0-0-62)	yes	6 months
K-Mag® (0-0-21.5-10.5Mg-21S)	yes	18 months
Urea (46-0-0)	yes	18 months
AMS, Urea, MAP (30%:35%:35% blend)	yes	12 months
DAP (18-46-0)	yes	18 months
MAP (11-52-0)	yes	18 months
SSP (0-16-0-11S-20Ca)	yes	18 months
MOP (0-0-60)	yes	18 months
SOP (0-0-48-16S)	yes	18 months
44-0-0	yes	18 months
10-10-10	yes	18 months
30-0-6 50%CRN	yes	18 months
Biosolids	yes	18 months
<b>Nutrient Stabilizers</b>		
NBPT (26.7%)	yes	6 months
NBPT (16%) + Duromide (27%)	yes	6 months
NBPT (17%) + DCD (23%)	yes	12 months
Nitrapyrin (25.97%)	yes	6 months
<b>Other Liquid Coatings</b>		
Micronutrients (various*)	yes	18 months

- \*Contact your product representative to determine compatibility if micronutrient coating contains a high concentration of heavy metals such as Cu or Zn.
- Solid fertilizers coated with PowerCoat have a shelf life of up to 18 months provided that the uncoated fertilizer's physical integrity specifications allow. The stability of PowerCoat coated fertilizers stored and handled in unpackaged bulk volumes varies by climate and operational practices.

- If PowerCoat is applied to a blend that also contains a N stabilizer or other nutrient coating, ensure PowerCoat is applied to the entire blend last.
- The addition of PowerCoat applied alone to dry fertilizer does not require a drying agent nor replace a drying agent if currently being used in the production process.
  - If applying PowerCoat with other coatings a drying agent may be needed dependent on the total volume of coatings applied to the dry fertilizer and fertilizer type.
  - Manufacturer recommends checking the first batch of impregnated fertilizer for flowability before discharging the entire batch from the mixer. This will provide an opportunity to adjust the amount of drying agent, if necessary, after the coatings are applied to the fertilizer.
  - Apply PowerCoat prior to adding drying agents.
  - **\*\*Note:** Drying agents are materials that are used to improve the flow properties of dry blend fertilizers. Depending on the time of year, weather conditions, amount and type of components in the fertilizer blend and the current condition of the components, drying agents may be required to improve the flow properties of even non impregnated fertilizers to allow application.
- For powdered coatings and site-specific compatibility information, please contact your product representative to determine compatibility.
- Curing treated fertilizer should be sufficiently dry before load out or bagging. Cure time may vary depending on impregnation rate and type of fertilizer being treated.
- PowerCoat product compatibility is based on common industry management practices. All risks shall be assumed by the buyer and user.

## TECHNICAL SUPPORT

Please contact a distributor near you, email [mb.agronomy@mosaicco.com](mailto:mb.agronomy@mosaicco.com), or visit our website at [cropputrition.com](http://cropputrition.com) for technical support.



Scan to  
download.

